

G500 (R) 5 FUNCTION LIGHT WORK CLASS TITANIUM GRABBER

The G500 is a five function hydraulic grabber manipulator made of titanium and developed for Observation and Light Work Class ROVs. Resistant, lightweight and reliable, it's designed for heavy duty ROV works improving performance and operation. It could be rate operated by any low power (1kW) hydraulic power unit and a solenoids (x5) valve pack fitted in the ROV vehicle.

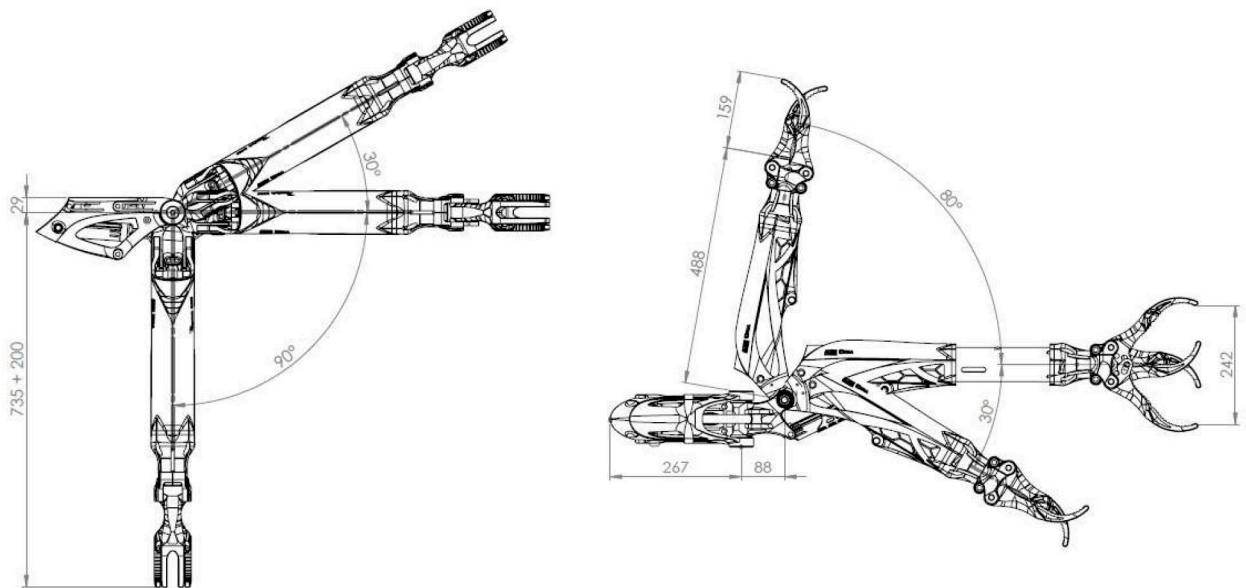

G500 5 FUNCTION TITANIUM GRABBER ARM SPECIFICATIONS:**GENERAL SPECIFICATIONS**

Depth rating (m)	3000
Weight in air (kg)	15
Weight in water (kg) w/ hyd. oil and hoses	13
Maximum reach (mm)	800
Lift at full extension (kg)	80 @ 150 bar
Maximum lift (kg)	100 @ 150 bar
Yaw Grip (kgf)	250
Yaw Torque (Nm)	80
Dimensions stowed LxWxH (mm)	290 x 230 x 783
Operating temperature (C)	-5 / +55
Construction Main Materials	Ti6Al4V Titanium AISI 316 SS

FUNCTIONS

SHOULDER Azimuth (Yaw) (deg)	120 (+90 / -30)
SHOULDER Pitch (deg)	110 (+80 / -30)
SHOULDER Extension (mm)	180
JAW Rotate (deg)	360 continuous
JAW Opening (mm)	255

HYDRAULIC REQUERIMENTS

Standard Hydraulic Oil	ISO 32
Operating pressure (bar)	Up to 206
Operating Flow Rate (lpm)	Min 1.5
Test Pressure (bar)	200
Max. Oil Temp. (C)	55

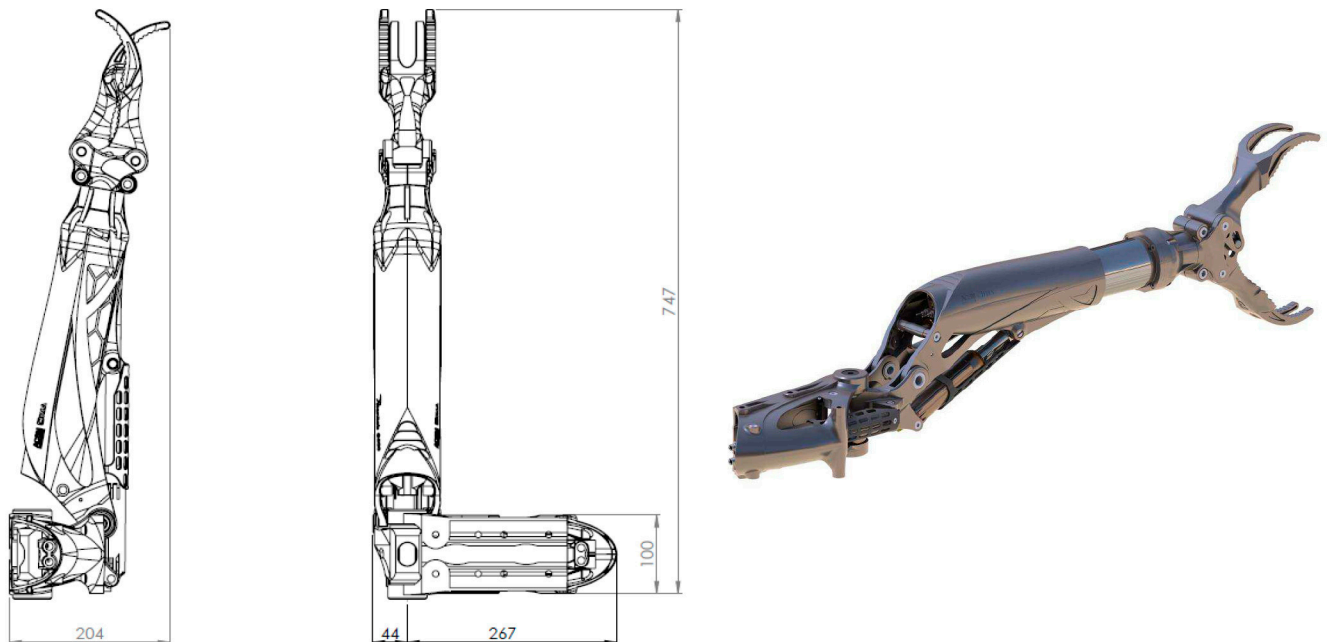

Titanrob Technologies SL

www.titanrob.cominfo@titanrob.com