

M501 (R) 5 FUNCTION LIGHT WORK CLASS TITANIUM MANIPULATOR

The M501 is a five function hydraulic manipulator made of titanium and developed for Observation and Light Work Class ROVs. Resistant, lightweight and reliable, it's designed for heavy duty ROV works improving performance and operation. It could be rate operated by any low power (1kW) hydraulic power unit and a solenoids (x5) valve pack fitted in the ROV vehicle.

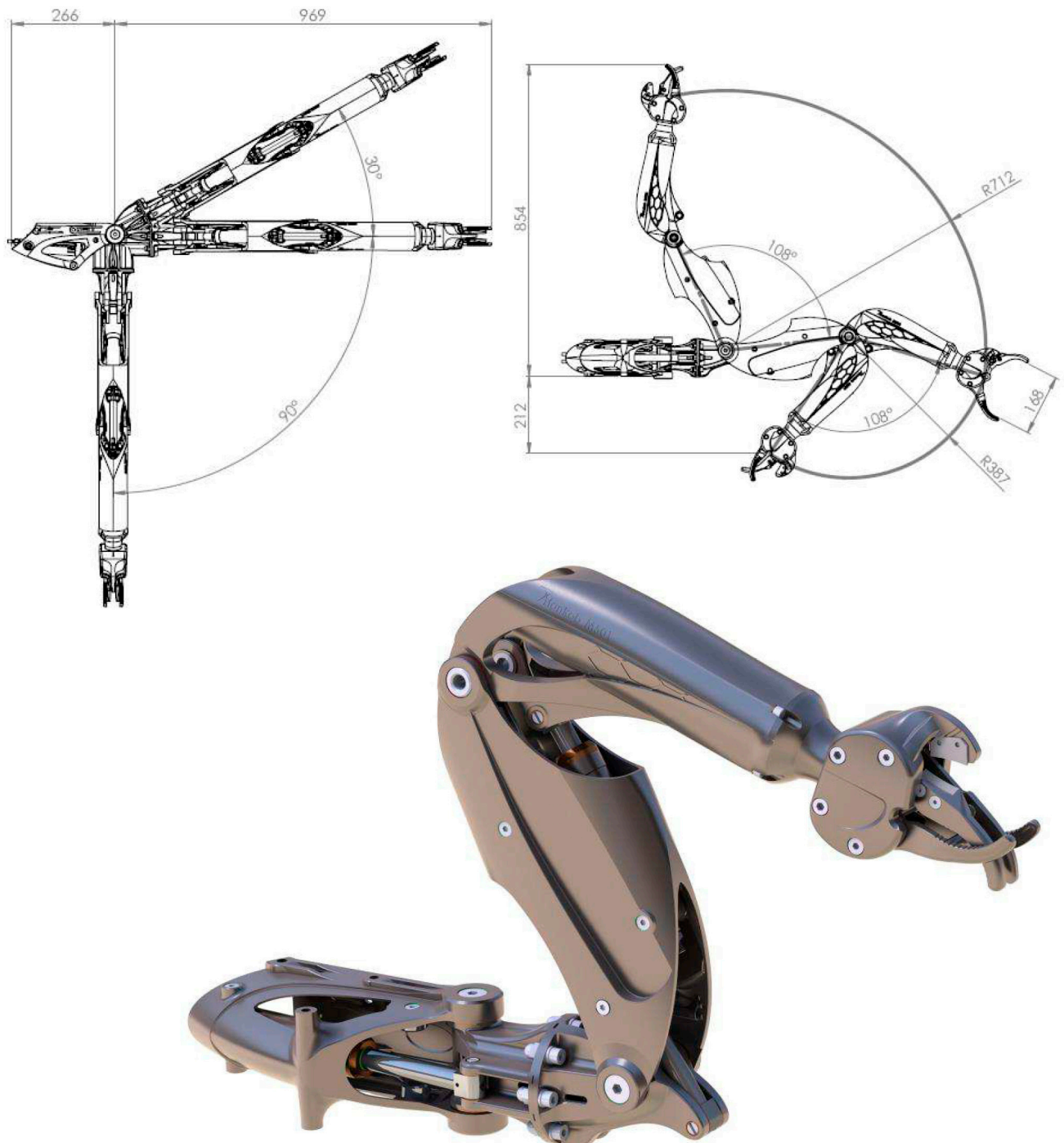

M501 5 FUNCTION TITANIUM MANIPULATOR ARM SPECIFICATIONS:**GENERAL SPECIFICATIONS**

Depth rating (m)	3000
Weight in air (kg)	14
Weight in water (kg) w/ hyd. oil and hoses	11
Maximum reach (mm)	950
Lift at full extension (kg)	40 @ 140 bar
Maximum lift (kg)	50 @ 140 bar
Yaw Grip (kgf)	80
Yaw Torque (Nm)	45
Dimensions stowed LxWxH (mm)	300x512x450
Operating temperature (C)	-5 / +55
Construction Main Materials	Ti6Al4V Titanium AISI 316 SS

FUNCTIONS

SHOULDER Azimuth (Yaw) (deg)	120 (+90 / -30)
SHOULDER Pitch (deg)	108
ELBOW Pitch (deg)	108
JAW Rotate (deg)	360 continuous
JAW Opening (mm)	168

HYDRAULIC REQUERIMENTS

Standard Hydraulic Oil	ISO 32
Operating pressure (bar)	Up to 206
Operating Flow Rate (lpm)	Min 1.5
Test Pressure (bar)	200
Max. Oil Temp. (C)	55

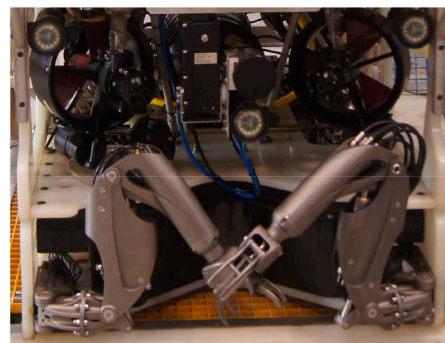
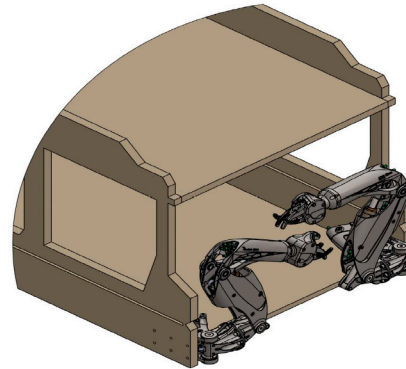
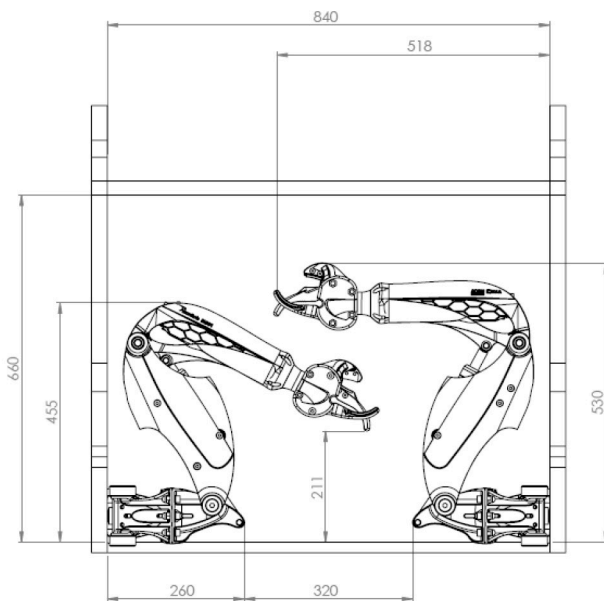

Titanrob Technologies SL

www.titanrob.cominfo@titanrob.com